

REV.
A

SAE AS5202

FEDERAL SUPPLY CLASS
4730

RATIONALE

AS5202A HAS BEEN REAFFIRMED TO COMPLY WITH THE SAE FIVE-YEAR REVIEW POLICY.

SAE Technical Standards Board Rules provide that: "This report is published by SAE to advance the state of technical and engineering sciences. The use of this report is entirely voluntary, and its applicability and suitability for any particular use, including any patent infringement arising therefrom, is the sole responsibility of the user." SAE reviews each technical report at least every five years at which time it may be revised, reaffirmed, stabilized, or cancelled. SAE invites your written comments and suggestions.

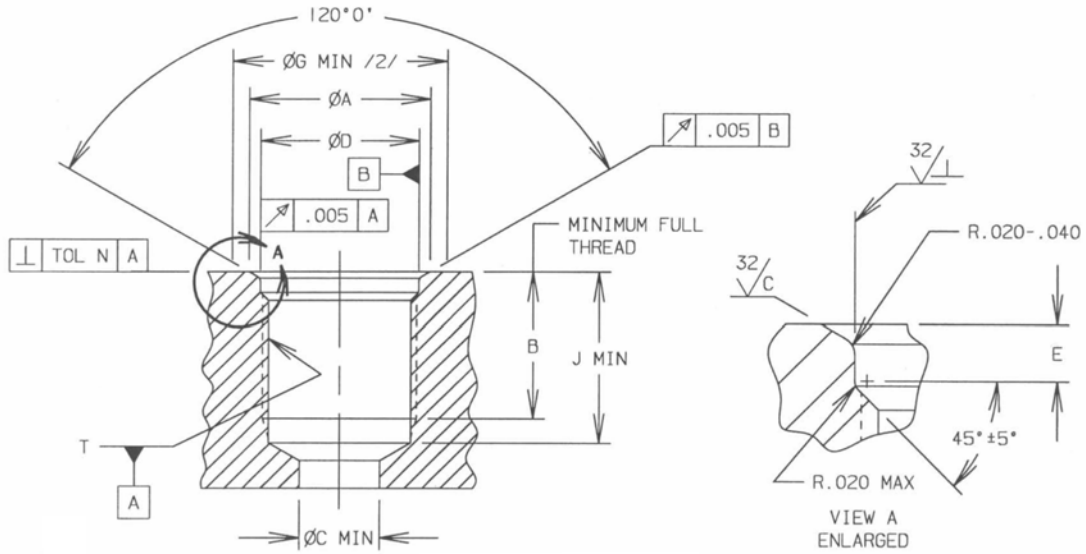
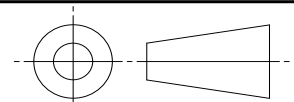

FIGURE 1 - FITTING END

SAE values your input. To provide feedback on this Technical Report, please visit <http://www.sae.org/technical/standards/AS5202A>

THIRD ANGLE PROJECTION



CUSTODIAN: G-3/G-3B

PROCUREMENT SPECIFICATION: NONE /1/

SAE Aerospace
An SAE International Group

AEROSPACE STANDARD

PORT OR FITTING END, INTERNAL
STRAIGHT THREAD,
DESIGN STANDARD

SAE AS5202
SHEET 1 OF 3

REV. A

Copyright 2013 SAE International

All rights reserved. No part of this publication may be reproduced, stored in a retrieval system or transmitted, in any form or by any means, electronic, mechanical, photocopying, recording, or otherwise, without the prior written permission of SAE.

TO PLACE A DOCUMENT ORDER: Tel: 877-606-7323 (inside USA and Canada)
Fax: 724-776-0790

Tel: +1 724-776-4970 (outside USA)
Email: CustomerService@sae.org

SAE WEB ADDRESS: <http://www.sae.org>

ISSUED 2001-08 REVISED 2005-05 REAFFIRMED 2013-01